

Hyperchill Plus-E

Green Industrial Water Chillers
for Precision Cooling



The new Hyperchill Plus-E range is a Green and Eco-Friendly solution, meeting the requirements laid out by the European F-Gas regulation (EU 517/2014), requiring the use of environmentally friendly low GWP refrigerants.

Most low GWP refrigerants belong to flammable safety classes, A2, A2L and A3. The use of the A1 Class (ISO817), R513A refrigerant by Hyperchill Plus-E, really sets it apart.

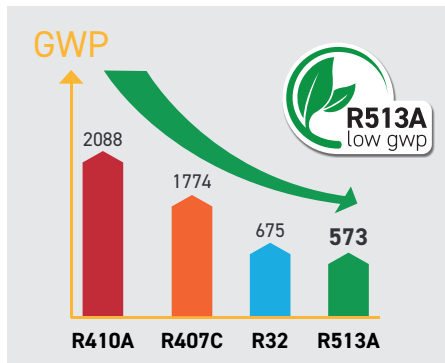

R513A being a non-flammable refrigerant, allows for Hyperchill Plus-E to be installed indoor or outdoor and conforms with standard building codes:

- No safety risk
- No need for flammable risk assessment
- No extra costs for installation



SAFETY CLASS



Non-flammable

Extremely compact and easy to use, Hyperchill Plus-E is designed for safe and reliable operation in the most varied working conditions, providing a precise and accurate control of the process fluid temperature. The availability of a wide range of accessories and options makes Hyperchill Plus-E a very flexible solution that fits the needs of all industrial applications.

Due to a non-ferrous hydraulic circuit, Hyperchill Plus-E ensures stable working conditions with maximum quality and cleanliness of the cooling fluid (water, water-glycol mixture, low viscosity fluids), improving the efficiency and productivity of the process and greatly reducing maintenance costs and plant downtime.

Each individual Hyperchill Plus-E unit is extensively tested to guarantee efficient operation and reliability in all working conditions.

Process Cooling Applications

- Coating Systems
- Chemical & Pharmaceutical Processes
- Plastics Processing
- Thermoform Machines
- Plasma Coating
- Medical Imaging Systems
- Food & Beverage Industry
- Injection Moulding
- Machine Tools
- Electroplating Baths
- Biogas & Natural Gas Treatment
- Compressed Air Treatment
- Laser Technology
- Extruders
- Surface Processing
- Welding Engineering
- Blow Mould Machines
- Flexographic Printing Systems
- Hydrogen
- CO2 Liquification



ENGINEERING YOUR SUCCESS.

Features and Benefits

Customer Benefits

- The use of Low GWP R513A refrigerant, which is non-flammable (Safety Class A1), allows for indoor and outdoor installation without any additional safety risk and cost.
- Thanks to its compact design, Hyperchill Plus-E provides a space saving and easy to install solution.
- Condenser filters, in addition to refrigeration and hydraulic circuit safety devices, prevent system downtime, protecting the investment.
- High performance components, as well as an oversized condenser and evaporator, ensure reliable operation. Even in extreme ambient conditions, Hyperchill Plus-E operates up to an ambient temperature of 48°C.
- The non-ferrous hydraulic circuit maintains the quality of the coolant ensuring stable working conditions, improving productivity and decreasing maintenance costs.

Product Features

Complete solution, easy to install and manage

- **Non ferrous hydraulic circuit:** non-ferrous water tank (stainless steel from ICEP005-E), stainless steel plate evaporator, non-ferrous pump with bypass prevent water from becoming corrosive
- **Pump and tank installed inside the chiller** provides a compact and easy to install solution; without pump and/or without tank solution available.
- **Electronic controllers with proprietary software** provide access to all the parameters of the units and allow special management for any specific need, with possibility for remote monitoring and 'master/slave' functioning.
- **Completely configurable** with many options and kits to fit the needs of industrial applications.
- **Condenser filters** reduce dirt, thereby preventing system downtime.
- As standard installed **differential pressure switch** that makes sure that the systems shuts down in the case that the circuit runs dry. Therefore the investment is protected.
- **Designed with eyebolts** (till ICEP015E) for easy handling.
- **IP54 standard** from ICEP008E for outdoor installations.
- **Independent condensing section** enables routine and special maintenance to be performed without stopping the system.
- Unit structure and design guarantee **full internal access** for easy maintenance.
- Models from ICEP022E designed with **fan step control** in order to work in low ambient temperatures down to -10°C.
- **All models equipped with MODBUS RTU interface**, ensuring a system monitoring (optional MODBUS TCP/IP).
- **Water and refrigerant manometers** permit full control of the working conditions.
- **Water pump: (standard 3bar) different head-pressures** available to meet the requirements of specific applications.
- **Visual level Indicator:** designed for open circuit versions.
- **High reliability and Low energy consumption**
- **Large built-in water tank** that provides a large thermal mass / storage capacity thus reducing the number of refrigerant compressor stop/starts and short cycling thereby increasing the compressor and chiller lifetime and reducing the energy consumption.
- **Maximum ambient temperature up to 48°C** on standard units, **Tropicalization and Low Ambient options** ensure reliable operation in extreme ambient conditions.
- **Oversized condensers and evaporators** guarantee high performing heat exchange increasing COP energy efficiency.
- **PID software developed and tested** to give the highest temperature consistency even at variable loads.
- Use of **compliant scroll compressors** (from ICEP008E) designed specifically for high efficiency and long life in industrial applications.
- **Low ambient speed-control** (optional) on fan-motor ensures constant performances at different temperatures, long lifetime of the fans and a reduction in absorbed power when ambient temperature is low.



Technical Data

Model ICEP-E		003E	005E	008E	011E	015E	022E	027E	034E	041E	055E	065E	080E	100E	120E	
Cooling capacity ¹	kW	2,9	4,9	7,8	11,1	15,0	21,9	26,6	33,1	40,2	56,3	65	78,3	103,7	120,6	
Total absorbed power ¹	kW	1,2	1,6	1,6	2,3	3,6	5,0	5,7	6,7	8,3	12,8	15,3	18,5	24,2	29,8	
EER ¹		2,38	3,16	4,79	4,78	4,10	4,40	4,64	4,95	4,82	4,55	4,25	4,25	4,10	4,04	
SEPR HT ²		NA	5,00	5,34	5,40	5,01	5,50	5,20	5,60	5,33	5,06	5,10	5,20	5,10	5,02	
Power Supply	V/ph/Hz	230/1/50					400/3/50									
Protection index		IP33					IP54									
Refrigerant		R513A														

Compressor

Type		piston					hermetic scroll									
Compressors / circuit							1/1					2/1		2/2		
Max.abs.power (1 compressor)	kW	1,1	1,5	2,5	3,5	5,4	6,5	8,7	10,8	11,3	10,8	11,3	13,1	17,9	22,1	

Axial fans

Quantity	no.	1					2					3				
Max.abs.power (1 fan)	kW	0,34	0,34	0,23	0,23	0,46	0,46	0,46	0,77	0,77	0,77	0,77	0,77	0,77	0,77	
Air flow	m ³ /h	1258	1258	3325	3325	5028	7823	10865	17337	17057	17057	17110	26832	26082	26082	

Pump P30

Max.abs.power	kW	0,4	0,4	0,9	0,9	1,0	1,3	1,3	2,2	2,2	2,2	2,2	3,3	3,3	3,3
Water flow (nom./ max) ¹	m ³ /h	0,5/1,9	0,8/1,9	1,3/4,5	1,9/4,5	2,6/5,4	3,8/9,6	4,6/9,6	5,7/18	6,9/18	9,7/18	11,2/18	13,6/31,2	17,8/31,2	20,7/31,2
Head pressure (nom./max) ¹	m H ₂ O	30/5	24/5	32/21,5	28,6/21,5	29/23	28/17,1	26,9/17,1	30/23,1	28,5/23,1	27,6/23,1	27/23,1	27,9/19	26,7/19	25,7/19

Weights and Dimensions

Width	mm	755	755	756	756	756	756	756	856	856	856	856	1050	1050	1050
Depth	mm	535	535	806	806	806	1206	1206	1956	1956	1956	1956	2500	2500	2500
Height	mm	801	801	1430	1430	1430	1430	1430	1680	1680	1680	1680	2012	2012	2012
Connections in/out	in	¾"	¾"	¾"	¾"	¾"	1"	1"	1½"	1½"	1½"	1½"	2"	2"	2"
Tank capacity	l	15	22,5	65	65	65	100	100	200	200	200	200	400	400	400
Weight (axial) ³	kg	80	91	165	175	180	235	250	485	510	580	595	875	1010	1030

Noise level

Sound pressure (axial) ⁴	dB(A)	52	52	50	50	51	52	52	53	54	55	55	58	59	59
-------------------------------------	-------	----	----	----	----	----	----	----	----	----	----	----	----	----	----

1) At water in/out temperature 20/15°C, glycol 0%, either 25°C ambient temperature (air-cooled models).

2) Value calculated in accordance with the European regulation (EU) 2016/2281 with regards to Ecodesign requirements for high temperature process chillers.

3) Includes refrigerant charge and pallet (version without options and accessories).

4) Sound pressure: average value obtained in free field on a reflective surface at a distance of 10 m from the condensate side of the machine and at a height of 1.6 m from the unit support base. Values with tolerance ± 2 dB. The sound levels refer to operation of the unit under full load in nominal conditions.

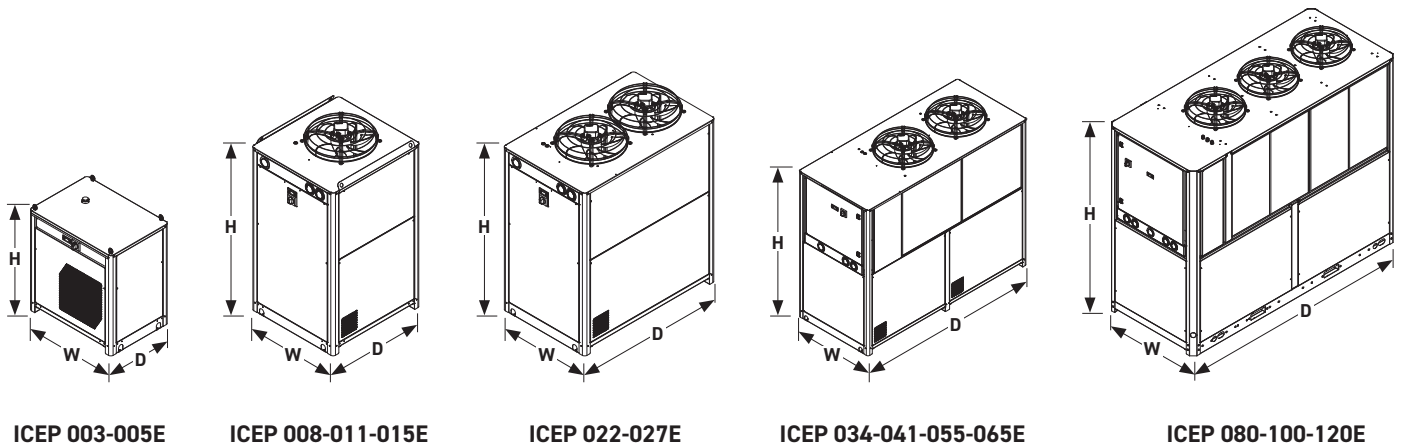

Product Specification

Options and Standard Features ✓ = Option ● = Standard Feature

	ICEP-003E	ICEP-005E	ICEP-008E	ICEP-011E	ICEP-015E	ICEP-022E	ICEP-027E	ICEP-034E	ICEP-041E	ICEP-055E	ICEP-065E	ICEP-080E	ICEP-100E	ICEP-120E
Differential Pressure Switch	●	●	●	●	●	●	●	●	●	●	●	●	●	●
MODBUS RTU	●	●	●	●	●	●	●	●	●	●	●	●	●	●
Eyebolts	●	●	●	●	●									
Non ferrous hydraulic circuit with water tank and 3 bar pump	●	●	●	●	●	●	●	●	●	●	●	●	●	●
Differential dynamic set point			●	●	●	●	●	●	●	●	●	●	●	●
Low Ambient -10°C with fan step control						●	●	●	●	●	●	●	●	●
Low ambient -10°C with fan speed control			✓	✓	✓									
Low ambient -20°C with fan speed control, crankcase heater and electrical panel heater			✓	✓	✓	✓	✓	✓	✓	✓	✓	✓	✓	✓
No Tank	✓	✓	✓	✓	✓	✓	✓	✓	✓	✓	✓	✓	✓	✓
No Tank & No Pump	✓	✓	✓	✓	✓	✓	✓	✓	✓	✓	✓	✓	✓	✓
No Pump	✓	✓	✓	✓	✓	✓	✓	✓	✓	✓	✓	✓	✓	✓
P50 (5 bar pump)	✓	✓	✓	✓	✓	✓	✓	✓	✓	✓	✓	✓	✓	✓
P15 (1,5 bar pump)			✓	✓	✓	✓	✓	✓	✓	✓	✓	✓	✓	✓
Dual pump P30 (3 bar pump)								✓	✓	✓	✓	✓	✓	✓
Dual pump P50 (5 bar pump)													on request	
Harting Plug for signals	✓	✓	✓	✓	✓	✓	✓	✓	✓	✓	✓			
Close Control (+/- 0,5°C)	✓	✓	✓	✓	✓	✓	✓	✓	✓	✓	✓		on request	
Low Water -10°C			✓	✓	✓	✓	✓	✓	✓	✓	✓	✓	✓	✓
Antifreeze Heating			✓	✓	✓	✓	✓	✓	✓	✓	✓	✓	✓	✓
BioEnergy & Aggressive ambient protection			✓	✓	✓	✓	✓	✓	✓	✓	✓	✓	✓	✓
Tropicalization (ambient temperature >48°C)														on request

Versions

Open Circuit	✓	✓														Available with ambient manual fill kit fitted
Closed Circuit		✓	✓	✓	✓	✓	✓	✓	✓	✓	✓	✓	✓	✓	✓	
Air Cooled with Axial Fans	✓	✓	✓	✓	✓	✓	✓	✓	✓	✓	✓	✓	✓	✓	✓	
Air Cooled with High Head Pressure Fan								✓	✓	✓	✓	✓	✓	✓	✓	
Water Cooled						✓	✓	✓	✓	✓	✓	✓	✓	✓	✓	

Accessories

Water fill kits: non-ferrous pressurized, automatic or ambient manual kits, for water filling in any installation.

Remote control kits: base version for remote ON/OFF and general alarm monitoring. Advanced version for complete remote unit monitoring and 'master/slave. functioning.

Wheels (ICEP003E - ICEP015E): for ease of transport.

Manual External By-Pass: Non-ferrous, externally manually adjustable allowing the correct flow through the system to be set.

Control panel cover: from ICEP008E, can be supplied already installed or loose.

MODBUS TCP/IP.

As the manufacturer of process chillers delivering water at a design temperature of 15°C, Parker Hannifin Manufacturing s.r.l., Gas Separation and Filtration Division EMEA, declares that Parker chillers are exempt from Ecodesign EU regulation 2016/2281.



Direct Cooling Solutions Ltd

Unit 38, Herald Way, Binley Industrial Estate, Coventry CV3 2RQ

Website: www.directcoolingsolutions.co.uk

Email: enquiries@directcoolingsolutions.co.uk

Telephone: 0808 175 9388